

Cost of Tender Document Fee Rs.500/



**NATIONAL INSTITUTE OF TECHNOLOGY
(Under the Ministry of HRD Govt. of India)
KURUKSHETRA-136119 (Haryana)**

INVITATION OF TENDERS

For supply of Furniture Items.

Tender Reference : **SO/Tender/NITK/2010**

Date of Commencement : **05.04.2010**
for Sale of Tender
Documents

Last date and Time for : **28.04.2010 at 2.30 PM**
Receipt of Tenders

Time and date of opening : **28.04.2010 at 3.00 PM**
of Tenders

Place of opening of : **Office of the Stores Officer,**
Tenders **NIT, Kurukshetra**

**INSTRUCTIONS TO TENDERERS
&
CONDITIONS OF CONTRACT**

1. System of Tendering

Two bid system (Technical & Commercial bids should be submitted in separate covers in following manner):

- (i) Bid containing technical specifications and Earnest Money Deposit.
- (ii) Bid containing financial offer.

The envelopes should be marked as Technical Bid and Financial Bid with reference numbers and submitted in one cover.

These bids will be opened in two stages on different dates. The bid containing technical specifications and Earnest Money deposit will be opened at Ist stage and if the same is found according to required specifications, the bid containing financial offer shall be opened in IInd stage

- 2. Tender must be sent in a properly sealed envelope with tender number and due date subscribed on the envelope addressed to the Stores Officer, NIT, Kurukshetra.
- 3. The price should be quoted on prescribed price schedule. All corrections must be attested by the tenderer.
- 4. All the columns of the tender form shall be duly and properly filled in separately. The rates and units shall not be overwritten in the price schedule. The rates shall be quoted both in figures and words. The Tender should be signed by the authorized signatory of the firm.
- 5. The tenderer shall deposit earnest money as specified in Schedule of Requirement alongwith Technical Bid in form of Account paying Bank Draft, Fixed deposit receipt, Bankers Cheque or Bank Guarantee from any Commercial Bank in favour of Director, National Institute of Technology, Kurukshetra. The tenders without Earnest Money shall be rejected.
- 6. In case the Tender Documents are downloaded from the website of the Institute for submission of the tender, the Tender Document Fee may be deposited through Demand Draft alongwith the Tender otherwise the tender may be rejected.
- 7. The successful tenderer shall furnish the Performance Security for an amount of 5% of total value of the equipment in form of Account Paying Bank Draft, Fixed Deposit Receipt, Bankers Cheque or Bank Guarantee from any Commercial Bank in favour of Director, National Institute of Technology, Kurukshetra for the period of completion of performance obligations and warranty period.

8. The required delivery period must be mentioned against each item. After the order has been placed, the goods must be delivered within the stipulated period or by the delivery period extended by the Director. In case of late delivery of goods the Director is entitled to recover as penalty from the tenderer a sum @ 0.5% of the total value of the goods for every week or part thereof and the maximum 10% of the total value of the goods for which the consignment is delayed beyond the due date.
9. The payment will be made after receipt of goods according to specifications, its installation and good working order. In case the goods are rejected these have to be removed by the supplier at his own cost. The rejected goods must be replaced by the supplier within 15 days of the dispatch of registered notice intimating that the goods have been rejected failing which the order may be cancelled and security forfeited.
10. No payment will be made in advance for any supplies under this tender. No claim for any duty, not stipulated in tender will be admitted at any stage.
11. The valid documentary proof of Sales Tax, VAT/Service Tax Registration No. & details of Income Tax registration (PAN) should be submitted alongwith tender. The taxes must be quoted clearly and separately. If the taxes are not quoted separately, it will be presumed that the rates quoted are inclusive of taxes. The rates quoted should be firm and include all charges. The material may be dispatched "FREIGHT PAID" where the offer is F.O.R. destination. The Form D is not issued by the Institute.
12. The consignment must be insured not exceeding at the rate of 1% of the value against the risk of breakdown and damage in transit with an Insurance Company if the goods are likely to get damaged in transit. In the absence of insurance the entire responsibility shall rest with the supplier and the Director shall not be bound to pay for such items, broken or damaged in transit.
13. In case of goods controlled by the Government, the tendered rates shall not be higher than the controlled rates.
14. Standard warrantee of minimum One Year or more should be mentioned in the tender. A list of users where similar equipment has been supplied in the past should be furnished with the tender.
15. Director of the Institute reserves the right to accept or reject any tender without assigning any reason.

16. The institute reserve the right to verify/seek confirmation of all original documentary evidence submitted by the venders in support of the tenders, specifications for eligible criteria. In case any information furnished by vender is found false/incorrect the tender will be rejected. The descriptive literature with full technical data and drawing/photos must be furnished alongwith the tender.
17. In case of dispute the decision of the Director shall be final. All above conditions will be enforced unless written orders of the Director are obtained relaxing any specific condition in any particular instance.
18. The tender shall remain valid for **90 days** from the date of opening of tender. Fax or conditional tenders shall not be accepted.
19. **Tender received beyond the fixed date and time shall not be accepted.**
20. The tenderers are required to quote their lowest rates in the very first instance and there shall be no negotiation in purchases. In case only one tender is received or only one tender remains according to specifications of the required goods, negotiations will be carried out.

PRICE SCHEDULE

Having examined the tender documents, the receipt of which is hereby duly acknowledged, we offer to supply the goods and services in conformity with the said tender documents at the rates shown below:

1	2	3	4	5	6	7	8	9	10	11
Sr. No	Particulars of the items	Unit	Ex-works, Ex-godown or C.I.F.	Customs Duty/excise Duty inclusive, if exclusive rates be given	Packing forwarding Octroi inclusive, if exclusive rates be given	Whether Sales Tax inclusive, if exclusive rates be given	Total Cost F.O.R. Kurukshetra	Delivery Period	Particulars of Manufacturers and Country in which manufactured	Remarks

N.B.: The price column should be properly filled. In case nothing is mentioned in the columns the price will be considered inclusive of Taxes, Excise Duty, packing and forwarding Octroi etc.

Dated the _____ Date of _____

Address with seal

Signature

SCHEDULE OF REQUIREMENTS

Sr. No.	Name of the Items	Qty.	Earnest Money (in Rs.)
1	Desk cum Bench 6'.0" x 18" x 36"	168 Nos.	1.61 Lacs
2	Desk cum Bench 7'.6" x 18" x 36"	168 Nos.	

Technical Specifications

Sr. No.	Description	Quantity	Rate	Amount
1.	<p>Supplying & Fixing of desk-cum-bench with inclined back suitable for comfortable posture and providing enough space for students to sit. The complete frame of desk-cum-bench made from MS pipe 50x25mm (2"x1") of 14 gauge. The size of desk is 6'.0"x18"x36" and size of seat/bench is 6'.0"x20"x18" (6'.0" for side rows) finished with MDF post forming board 25mm thick both side laminated with edge bending (full back of bench) with Powder Coated painting on MS frame design & colour will be finalized by the committee at the time of manufacturing complete in all respect including 4' long fastener for fixing. (Drawing attached for details)</p>	168 Nos.		
2	<p>Supplying & Fixing of desk-cum-bench with inclined back suitable for comfortable posture and providing enough space for students to sit. The complete frame of desk-cum-bench made from MS pipe 50x25mm (2"x1") of 14 gauge. The size of desk is 7'.6" x18"x36" and size of seat/bench is 7'.6"x20"x18" (7'.6" in length for middle rows) finished with MDF post forming board 25mm thick both side laminated with edge bending (full back of bench) with Powder Coated painting on MS frame design & colour will be finalized by the committee at the time of manufacturing complete in all respect including 4' long fastener for fixing. (Drawing attached for details)</p>	168 Nos.		

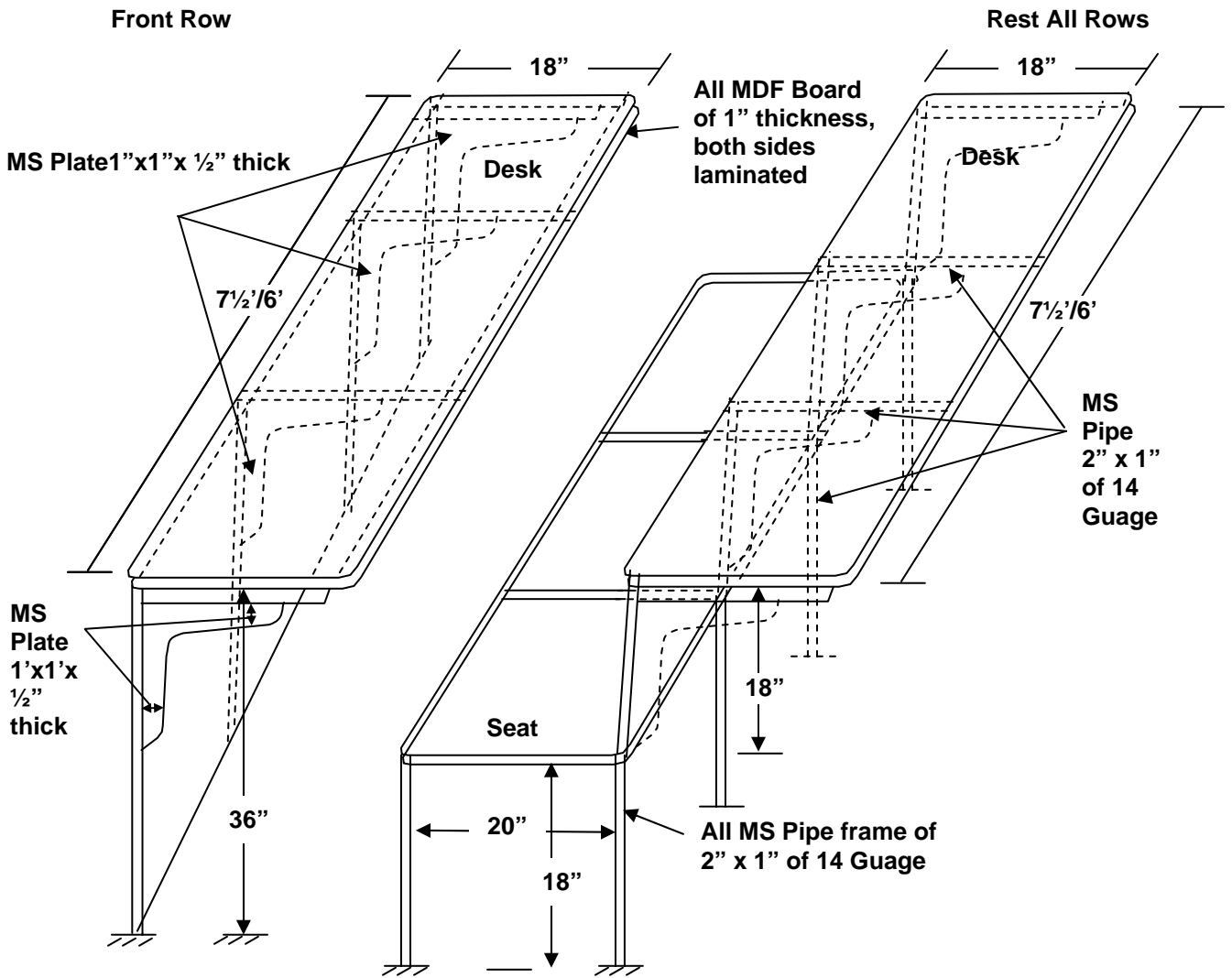

MODEL BANK GUARANTEE FORMAT FOR FURNISHING EMD

Whereas
(hereinafter called the “tenderer”)
has submitted their offer dated
for the supply of
(hereinafter called the “tender”)
against the purchaser’s tender enquiry No.
KNOW ALL MEN by these presents that WE
ofhaving our registered office at
.....are bound unto
.....
(hereinafter called the “Purchaser”)
in the sum of
for which payment will and truly to be made to the said Purchaser, the Bank binds itself, its
successors and assigns by these presents. Sealed with the Common Seal of the said Bank this
..... day of20...

THE CONDITIONS OF THIS OBLIGATION ARE;

- (1) If the tenderer withdraws or amends, impairs or derogates from the tender in any respect within the period of validity of this tender.

- (2) If the tenderer having been notified of the acceptance of his tender by the Purchaser during the period of its validity:
 - a) If the tenderer fails to furnish the Performance Security for the due performance of the contract.
 - b) Fails or refuses to accept/execute the contract.

WE undertake to pay the Purchaser up to the above amount upon receipt of its first written demand, without the Purchaser having to substantiate its demand provided that in its demand the Purchaser will note that the amount claimed by it is due to it owing to the occurrence of one or both the two conditions, specifying the occurred condition or conditions.

This guarantee will remain in force upto and including 45 days after the period of tender validity and any demand in respect thereof should reach the Bank not later than the above date.

(Signature of the authorized officer of the Bank)

Name and designation of the officer

Seal, name & address of the Bank and address of the Branch

MODEL BANK GUARANTEE FORMAT FOR PERFORMANCE SECURITY

To
The Director, National Institute of Technology, Kurukshetra

WHEREAShas
(name and address of the supplier) (hereinafter called "the supplier")
undertaken, in pursuance of contract No.dated
to supply (description of goods and services) (hereinafter called "the contract").

AND WHEREAS it has been stipulated by you in the said contract that the supplier shall furnish you with a bank guarantee by a scheduled commercial recognized by you for the sum specified therein as security for compliance with its obligations in accordance with the contract.

AND WHEREAS we have agreed to give the supplier such a bank guarantee;

NOW THEREFORE we hereby affirm that we are guarantors and responsible to you, on behalf of the supplier, up to a total of
.....(amount of the guarantee in words and figures), and we undertake to pay you, upon your first written demand declaring the supplier to be in default under the contract and without cavil or argument, any sum or sums within the limits of (amount of guarantee) as aforesaid, without your needing to prove or to show grounds or reasons for your demand or the sum specified therein.

We hereby waive the necessity of your demanding the said debt from the supplier before presenting us with the demand.

We further agree that no change or addition to or other modification of the terms of the contract to be performed thereunder or of any of the contract documents which may be made between you and the supplier shall in any way release us from any liability under this guarantee and we hereby waive notice of any such change, addition or modification.

This guarantee shall be valid until theday of20

(Signature of the authorized officer of the Bank)

Name and designation of the officer

Seal, name & address of the Bank and address of the Branch