

Cost of Tender Document Fee Rs.500/



**NATIONAL INSTITUTE OF TECHNOLOGY  
(Under the Ministry of HRD Govt. of India)  
KURUKSHETRA-136119 (Haryana)**

**INVITATION OF TENDERS**

**Supply of Furniture Items for Additional Girls Hostel.**

Tender Reference : **SO/Tender/NITK/2010**

Date of Commencement : **19.04.2010**  
for Sale of Tender  
Documents

Last date and Time for : **10.05.2010 at 2.30 PM**  
Receipt of Tenders

Time and date of opening : **10.05.2010 at 3.00 PM**  
of Tenders

Place of opening of : **Office of the Stores Officer,**  
Tenders **NIT, Kurukshetra**

**INSTRUCTIONS TO TENDERERS  
&  
CONDITIONS OF CONTRACT**

**1. System of Tendering**

Two bid system (Technical & Commercial bids should be submitted in separate covers in following manner):

- (i) Bid containing technical specifications and Earnest Money Deposit.
- (ii) Bid containing financial offer.

The envelopes should be marked as Technical Bid and Financial Bid with reference numbers and submitted in one cover.

These bids will be opened in two stages on different dates. The bid containing technical specifications and Earnest Money deposit will be opened at Ist stage and if the same is found according to required specifications, the bid containing financial offer shall be opened in IInd stage

- 2. Tender must be sent in a properly sealed envelope with tender number and due date subscribed on the envelope addressed to the Stores Officer, NIT, Kurukshetra.
- 3. The price should be quoted on prescribed price schedule. All corrections must be attested by the tenderer.
- 4. All the columns of the tender form shall be duly and properly filled in separately. The rates and units shall not be overwritten in the price schedule. The rates shall be quoted both in figures and words. The Tender should be signed by the authorized signatory of the firm.
- 5. The tenderer shall deposit earnest money as specified in Schedule of Requirement alongwith Technical Bid in form of Account paying Bank Draft, Fixed deposit receipt, Bankers Cheque or Bank Guarantee from any Commercial Bank in favour of Director, National Institute of Technology, Kurukshetra. The tenders without Earnest Money shall be rejected.
- 6. In case the Tender Documents are downloaded from the website of the Institute for submission of the tender, the Tender Document Fee may be deposited through Demand Draft alongwith the Tender otherwise the tender may be rejected.
- 7. The successful tenderer shall furnish the Performance Security for an amount of 5% of total value of the equipment in form of Account Paying Bank Draft, Fixed Deposit Receipt, Bankers Cheque or Bank Guarantee from any Commercial Bank in favour of Director, National Institute of Technology, Kurukshetra for the period of completion of performance obligations and warranty period.

8. The required delivery period must be mentioned against each item. After the order has been placed, the goods must be delivered within the stipulated period or by the delivery period extended by the Director. In case of late delivery of goods the Director is entitled to recover as penalty from the tenderer a sum @ 0.5% of the total value of the goods for every week or part thereof and the maximum 10% of the total value of the goods for which the consignment is delayed beyond the due date.
9. The payment will be made after receipt of goods according to specifications, its installation and good working order. In case the goods are rejected these have to be removed by the supplier at his own cost. The rejected goods must be replaced by the supplier within 15 days of the dispatch of registered notice intimating that the goods have been rejected failing which the order may be cancelled and security forfeited.
10. No payment will be made in advance for any supplies under this tender. No claim for any duty, not stipulated in tender will be admitted at any stage.
11. The valid documentary proof of Sales Tax, VAT/Service Tax Registration No. & details of Income Tax registration (PAN) should be submitted alongwith tender. The taxes must be quoted clearly and separately. If the taxes are not quoted separately, it will be presumed that the rates quoted are inclusive of taxes. The rates quoted should be firm and include all charges. The material may be dispatched "FREIGHT PAID" where the offer is F.O.R. destination. The Form D is not issued by the Institute.
12. The consignment must be insured not exceeding at the rate of 1% of the value against the risk of breakdown and damage in transit with an Insurance Company if the goods are likely to get damaged in transit. In the absence of insurance the entire responsibility shall rest with the supplier and the Director shall not be bound to pay for such items, broken or damaged in transit.
13. In case of goods controlled by the Government, the tendered rates shall not be higher than the controlled rates.
14. Standard warrantee of minimum One Year or more should be mentioned in the tender. A list of users where similar equipment has been supplied in the past should be furnished with the tender.
15. Director of the Institute reserves the right to accept or reject any tender without assigning any reason.

16. The institute reserve the right to verify/seek confirmation of all original documentary evidence submitted by the venders in support of the tenders, specifications for eligible criteria. In case any information furnished by vender is found false/incorrect the tender will be rejected. The descriptive literature with full technical data and drawing/photos must be furnished alongwith the tender.
17. In case of dispute the decision of the Director shall be final. All above conditions will be enforced unless written orders of the Director are obtained relaxing any specific condition in any particular instance.
18. The tender shall remain valid for **90 days** from the date of opening of tender. Fax or conditional tenders shall not be accepted.
19. **Tender received beyond the fixed date and time shall not be accepted.**
20. The tenderers are required to quote their lowest rates in the very first instance and there shall be no negotiation in purchases. In case only one tender is received or only one tender remains according to specifications of the required goods, negotiations will be carried out.

### **PRICE SCHEDULE**

Having examined the tender documents, the receipt of which is hereby duly acknowledged, we offer to supply the goods and services in conformity with the said tender documents at the rates shown below:

1	2	3	4	5	6	7	8	9	10	11
Sr. No	Particulars of the items	Unit	Ex-works, Ex-godown or C.I.F.	Customs Duty/excise Duty inclusive, if exclusive rates be given	Packing forwarding Octroi inclusive, if exclusive rates be given	Whether Sales Tax inclusive, if exclusive rates be given	Total Cost F.O.R. Kurukshetra	Delivery Period	Particulars of Manufacturers and Country in which manufactured	Remarks

N.B.: The price column should be properly filled. In case nothing is mentioned in the columns the price will be considered inclusive of Taxes, Excise Duty, packing and forwarding Octroi etc.

Dated the \_\_\_\_\_ Date of \_\_\_\_\_

Address with seal

Signature

## SCHEDULE OF REQUIREMENTS

<b>Sr. No.</b>	<b>Name of the Items</b>	<b>Qty.</b>	<b>Earnest Money ( in Rs.)</b>
1	Steel Cots	200 Nos.	} 93000/-
2	Steel Study Chair with Arms	350 Nos.	
3	Study Cum Computer Table	350 Nos.	
4	Dinning Table 8'x4' with sunmica top	20 Nos.	
5	Easy Chair (Common Rooms & Rooms)	150 Nos.	

## Technical Specifications

Sr. No.	Description	Qty.
<b>1</b>	<b>Steel Cots</b>	
	Fabrication of 1.5"x1.5" square pipe 16 gauge heavy duty & 2 supports 1"x1" square pipe 16 gauge by welding. After fabrication of cot structure pipe ends properly closed top, bottom & sides by welding M.S. Plate 5mm thick Triangle side 19mm fitting properly by welding all side of cots. After completion of fabrication cot grinding and remove sharp edges properly rubbing of cot by Emry paper. And filling Metallic putty in welding & Pin holes then steel primer apply 1 coat or 2 coat of Asian paints of Enamel black colour providing and fixing of ply board ISI Mark 12mm thick (BWR) Boiled Water Resistance with teak wood half round beading fixing all side of board duly polished of board sealer two or more coats touch wood by spray, Fabrication of cot as per drawing attached.	200 Nos.
<b>2</b>	<b>Steel Study Chair with Arms</b>	
	Fabrication of chair 1" square pipe 16 gage heavy duty After fabrication of chair pipe ends properly closed by welding then edges properly grinding & rubbing structure of chair by Emry paper. And filling synthetic puttin in welding & pin holes then steel primer apply 1 coat or 2 coats of Asian paints of Enamel black colours. Providing & fixing of heavy rubber boots in top & bottom. Seats & back of 12mm thick ply ISI (BWR)Boiled Water Resistance size of seats 16" x 18" and size of back 13" x 18" with polished chair fabrication as per drawing attached.	350 Nos.
<b>3</b>	<b>Study Cum Computer Table</b>	
	Computer table, frame fabricated out of 1" square pipe of 16 gauge. Bottom side 2"x1" pipe of 16 gauge. Top, Side, shelves, planks are to be made of 19mm thick commercial board with 1mm thick Marino matt type sunmica. Table should have provision for printer, UPS & one shelf/drawer with sliding telescopic channel for keyboard. The sliding shelf should have maximum outward movement of 10" for easy working on keyboard. The rear and front of the keyboard platform is to be provided with spirit polished teak wood beading to prevent accidental falling of keyboard. Size of the tabletop should be 4'x2.5' with round corners. All steel components should be pretreated with anticorrosion before being painted with black colour. Fabrication of cot as per drawing attached.	350 Nos.
<b>4</b>	<b>Dinning Table 8'x4' with sun mica top</b>	
	Fabrication of Dinning Table M.S. pipe 2"x2" heavy duty 16 gage table top size 8'x4' height 29" fabrication by welding after welding, grinding, sharp edge removing. Pipe's ends properly close by welding & griding table structure leg bottom & fitting M.S. Plate by welding in corners and then grinding M.S Plate size 3"x3" thickness 6mm. Table structure rubbing emry paper and filling Metallic putty in welding and holes. Then steel primer 1coat or 2 coat Enamel Asian Paint full structure of dinning table. Providing and fixing of ISI mark board (BWR)Boiled Water Resistance 1mm thick Sun mica fixing beading fixing all side of board. Board polised by sealer 2 coat and 1 coat touch wood by spray all will be done as per drawing attached.	20 Nos.

5	<b>Easy Chair (Common Rooms &amp; Rooms)</b>	
	The armed chair is to be ergonomically designed and fabricated out of C.R. pipe of 14 gauge duly painted. Chair seat of 17"x19" & back 17"x17" made up of flexible premoulded polyurethane foam with support of 12mm ply (edges round) at bottom tightened with three plates of 4mm steel strip of 1" width. Superior quality cloth in crape of desired shade (sample to be provided with quotation giving serial number to each sample).Suitable PVC beading is to be fixed all around seat and back. All steel components to be powder coated paintin. Design & Shape as per Godrej standard model CH-03.	150 Nos.

**TERMS & CONDITIONS**

1. Delivery period will be 45 days from the date of issue of orders.
2. The sample of the furniture items to be submitted alongwith Tender. All samples should be as per specifications otherwise sample & technical bid will be rejected.
3. Warranty period will be one year.
4. Approved samples will be retained by the Institute and final supply of items should be strictly as per approved samples.

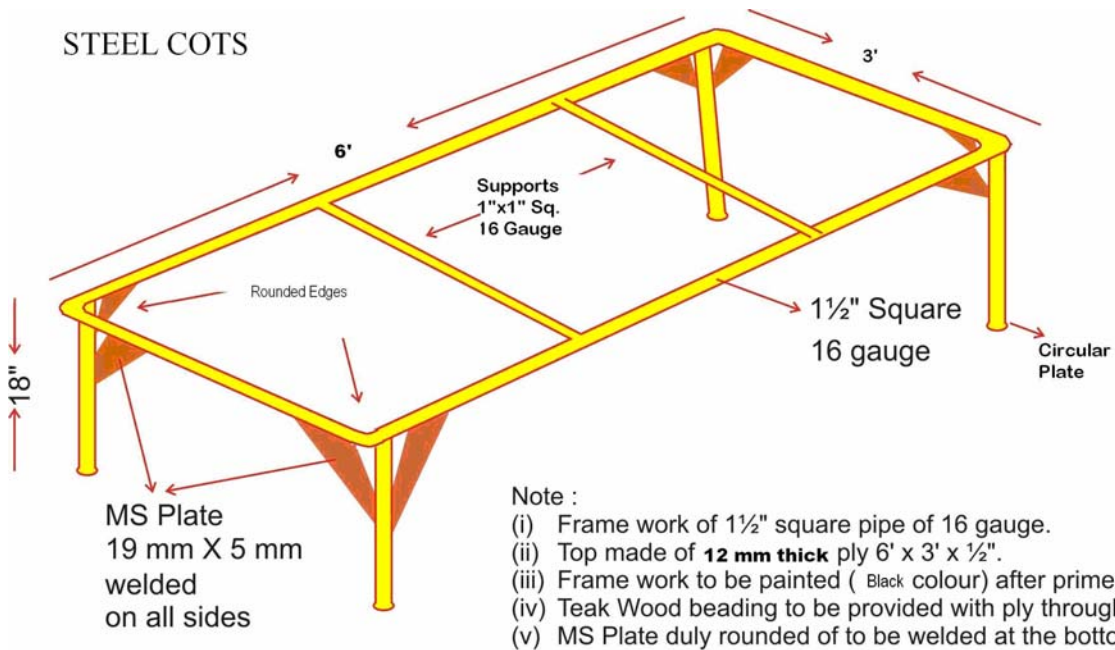
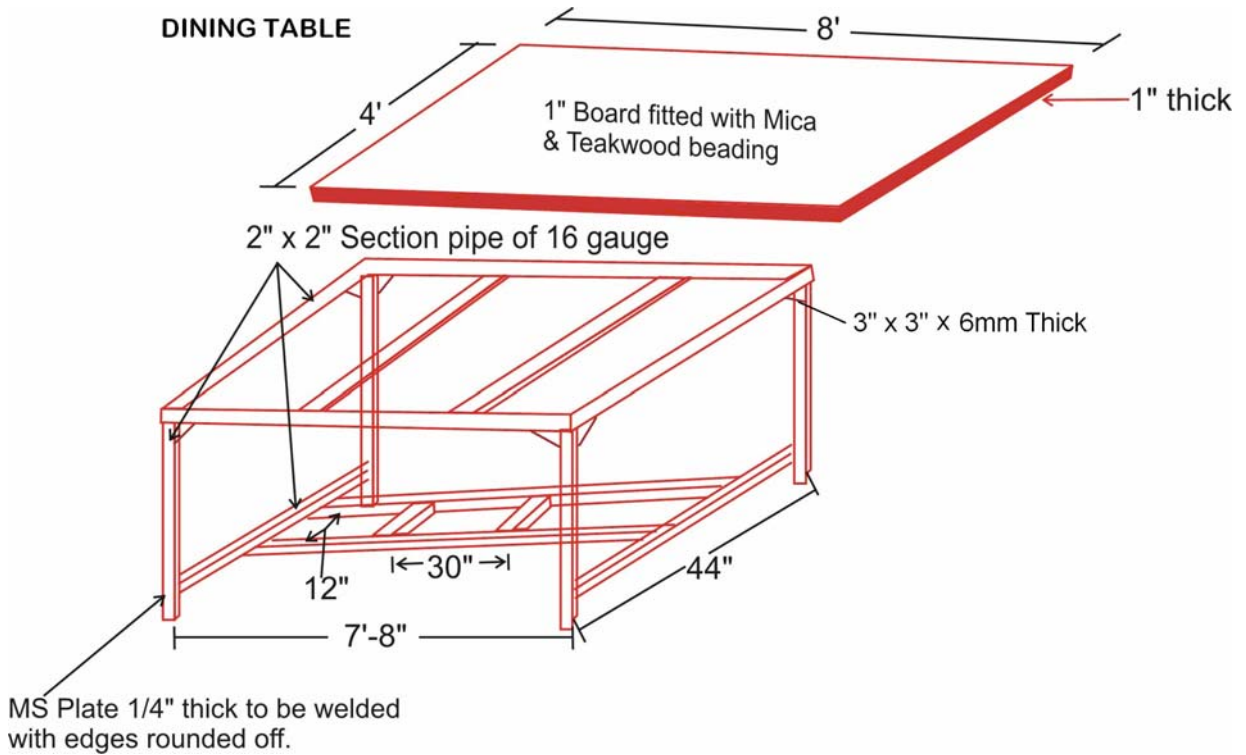

# Steel Study Chair

BACK FIXED TO FR.  
BY MEANS OF 5 N

12 MM TH. PLY  
ISI BWR

SEAT  
HAVING  
12 MM TH.  
PLY ISI  
BMR

25 MM M.S. SQ TUBE  
OF 16 GAUGE

HARD RUBBER SHOE

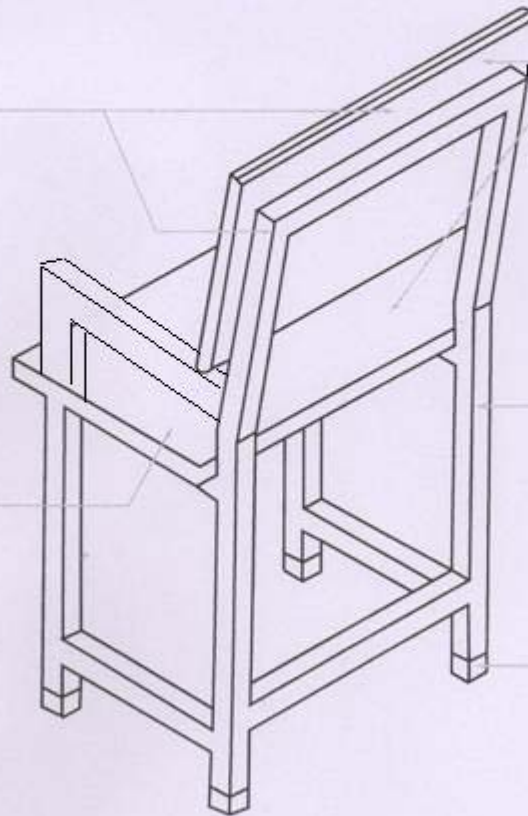

# Study cum Computer Table

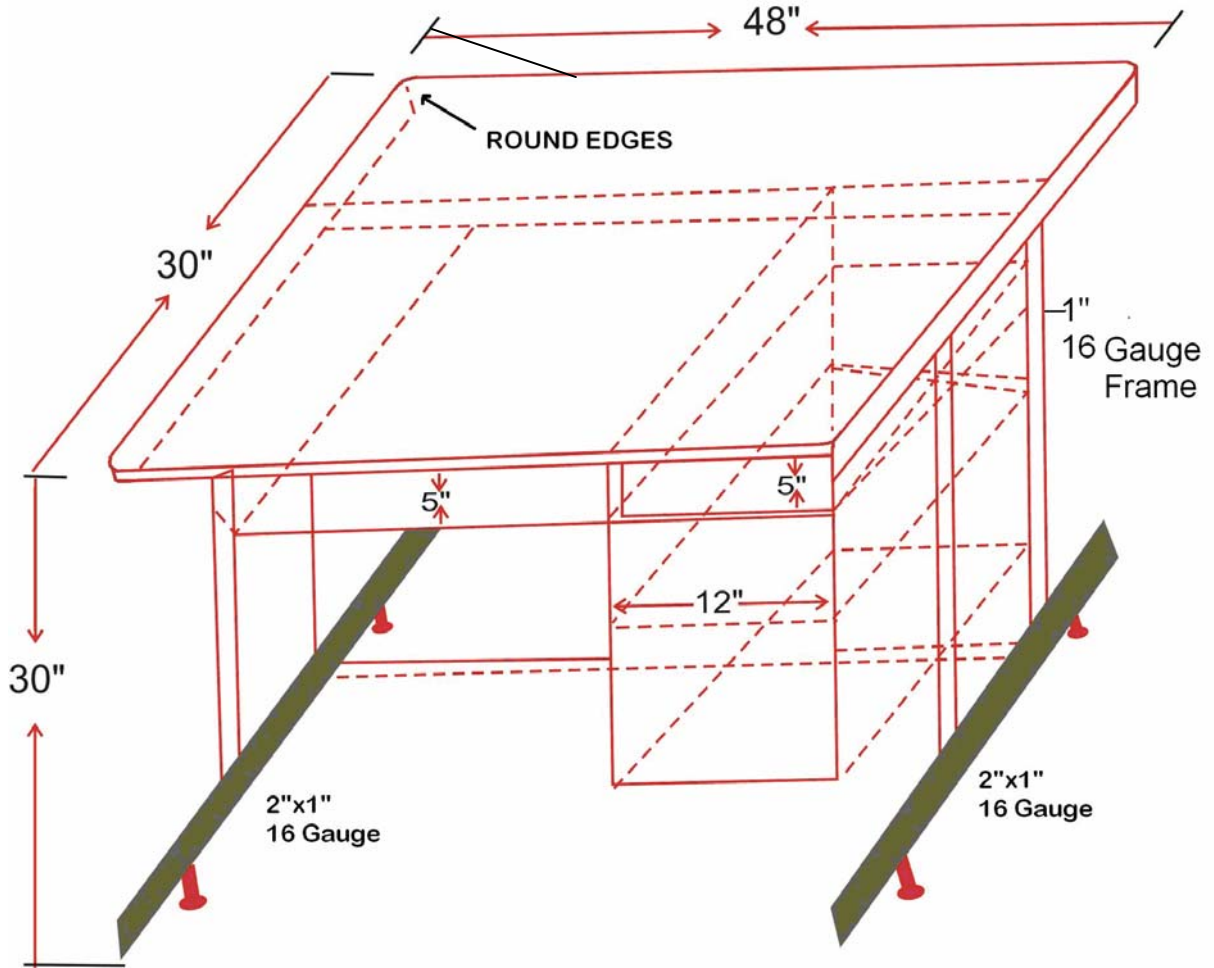

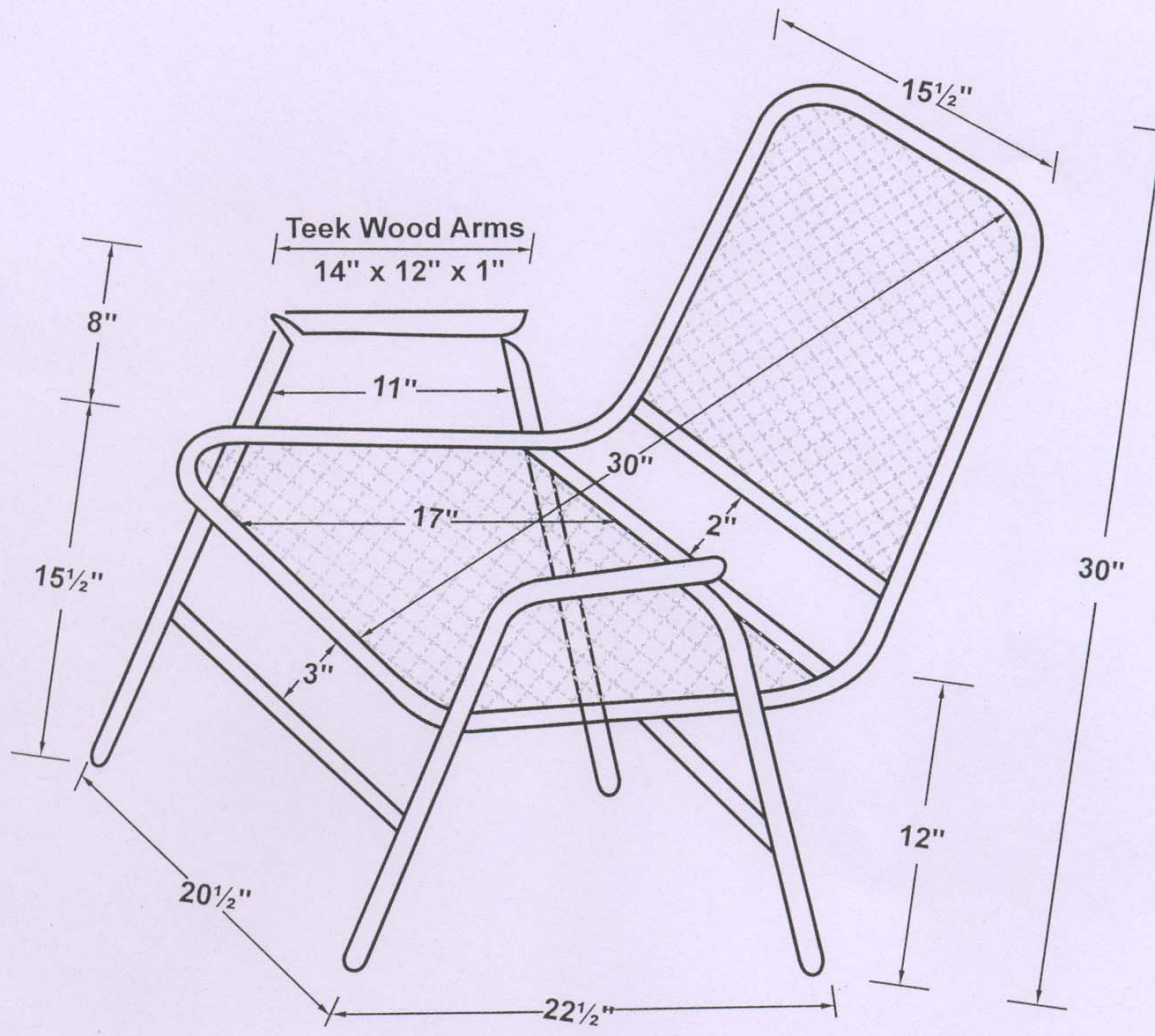

# EASY CHAIR (STEEL)

**MODEL BANK GUARANTEE FORMAT FOR FURNISHING EMD**

Whereas .....  
(hereinafter called the “tenderer”)  
has submitted their offer dated .....  
for the supply of .....  
(hereinafter called the “tender”)  
against the purchaser’s tender enquiry No. ....  
KNOW ALL MEN by these presents that WE .....  
of .....having our registered office at  
.....are bound unto .....  
.....  
(hereinafter called the “Purchaser”)  
in the sum of .....  
for which payment will and truly to be made to the said Purchaser, the Bank binds itself, its  
successors and assigns by these presents. Sealed with the Common Seal of the said Bank this  
..... day of .....20...

**THE CONDITIONS OF THIS OBLIGATION ARE;**

- (1) If the tenderer withdraws or amends, impairs or derogates from the tender in any respect within the period of validity of this tender.
  
- (2) If the tenderer having been notified of the acceptance of his tender by the Purchaser during the period of its validity:
  - a) If the tenderer fails to furnish the Performance Security for the due performance of the contract.
  - b) Fails or refuses to accept/execute the contract.

WE undertake to pay the Purchaser up to the above amount upon receipt of its first written demand, without the Purchaser having to substantiate its demand provided that in its demand the Purchaser will note that the amount claimed by it is due to it owing to the occurrence of one or both the two conditions, specifying the occurred condition or conditions.

This guarantee will remain in force upto and including 45 days after the period of tender validity and any demand in respect thereof should reach the Bank not later than the above date.

(Signature of the authorized officer of the Bank)

Name and designation of the officer

Seal, name & address of the Bank and address of the Branch

**MODEL BANK GUARANTEE FORMAT FOR PERFORMANCE SECURITY**

To  
The Director, National Institute of Technology, Kurukshetra

WHEREAS .....has  
(name and address of the supplier) (hereinafter called "the supplier")  
undertaken, in pursuance of contract No. ....dated .....  
to supply (description of goods and services) (hereinafter called "the contract").

AND WHEREAS it has been stipulated by you in the said contract that the supplier shall furnish you with a bank guarantee by a scheduled commercial recognized by you for the sum specified therein as security for compliance with its obligations in accordance with the contract.

AND WHEREAS we have agreed to give the supplier such a bank guarantee;

NOW THEREFORE we hereby affirm that we are guarantors and responsible to you, on behalf of the supplier, up to a total of .....  
.....(amount of the guarantee in words and figures), and we undertake to pay you, upon your first written demand declaring the supplier to be in default under the contract and without cavil or argument, any sum or sums within the limits of (amount of guarantee) as aforesaid, without your needing to prove or to show grounds or reasons for your demand or the sum specified therein.

We hereby waive the necessity of your demanding the said debt from the supplier before presenting us with the demand.

We further agree that no change or addition to or other modification of the terms of the contract to be performed thereunder or of any of the contract documents which may be made between you and the supplier shall in any way release us from any liability under this guarantee and we hereby waive notice of any such change, addition or modification.

This guarantee shall be valid until the .....day of .....20

(Signature of the authorized officer of the Bank)

Name and designation of the officer

Seal, name & address of the Bank and address of the Branch